

HSST

- Network
- Signal Tower
- Signal Light
- Revolving Warning Light
- Cube Tower
- Audibles
- Hybrid Signaling Devices
- LED Illumination
- Options



Compatible with WD-Z2 Series



[When lights are off]

Control signal lights ON and OFF with a 3-point switch for red, amber, and green.
*Cannot control flashing / buzzer.

Colors	Red, Amber, Green, (Clear globe)
Globe	Polycarbonate resin, high shock resistance and heat resistance

Maintenance-free LED illumination
3-button switch box with mounting screws
AC power adapter (100-240VAC) with 5ft. cable
LED colors: red, amber, green.



Contents

- The HSST Kit Includes:
- ① Signal Tower x1
 - ② Long pole x 1
 - ③ Metal fitting for mounting x 1
 - ④ Screw x 1
 - ⑤ Bracket x 1
 - ⑥ Mounting screws x 2
 - ⑦ Double-sided tape x 1
 - ⑧ Switch box x 1
 - ⑨ AC adaptor x 1

Assembly Process



Mounting example

Assembly Process Alarms

- Problem Alarm
- Parts Low Alarm
- Help Needed Alarm

Call center



Call status display

- Call for Help
- Oh hold
- Call in progress

- IP54
- RoHS
- 50 ϕ
- Switch ON / OFF
- UL

(For signals only, switch box is IP20)

Specifications

Model		HSST-3M2-RYG		Mass (Tolerance: $\pm 10\%$)	Signal Tower (short pole)	0.36kg
Rated Voltage		100 - 240V AC (50/60Hz)			Signal Tower (long pole)	0.47kg
Operating Voltage Range		Rated Voltage $\pm 10\%$			Bracket	0.33kg
Rated Power Consumption	Maximum	When all tiers are illuminated			Switch box	0.07kg
		4W			AC Adaptor	0.14kg
Operating Temperature Range		0°C - +40°C			Metal fitting for mounting, screw	0.05kg
Mounting location		Indoors				
Mounting direction		Upright				

Dimensions (mm)

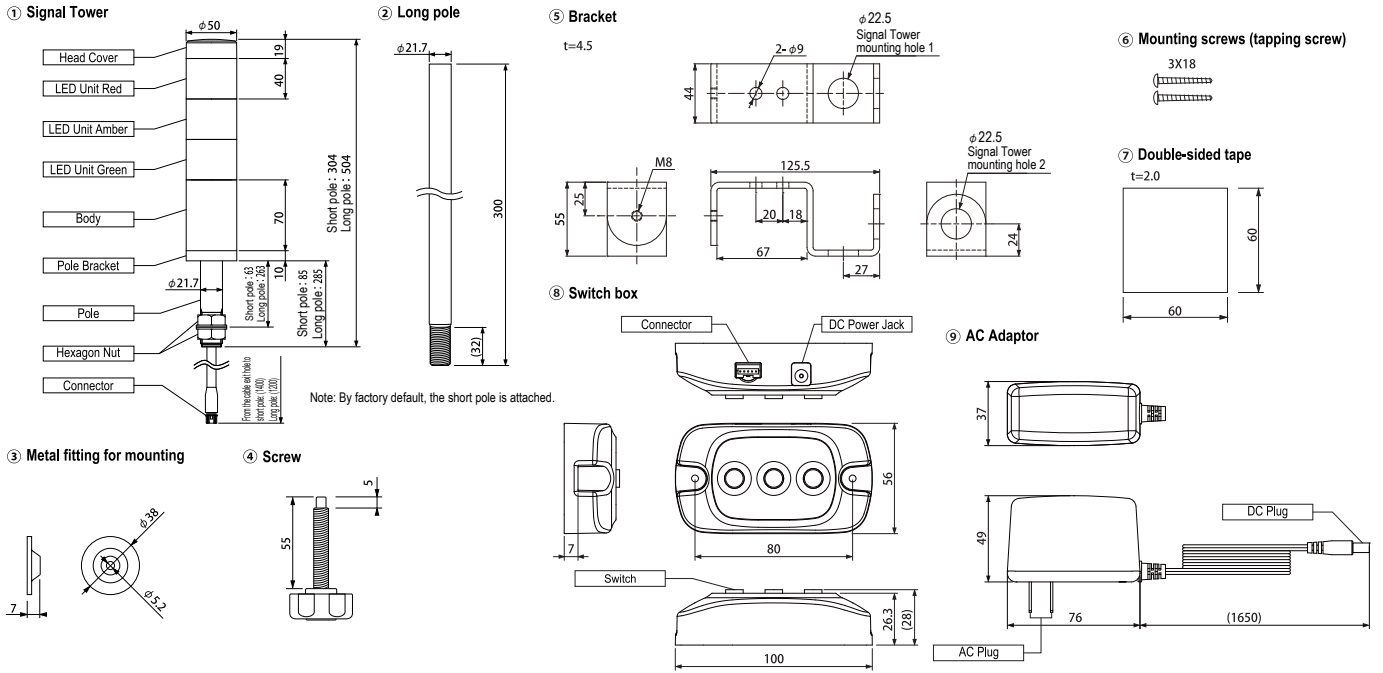

Mounting Method

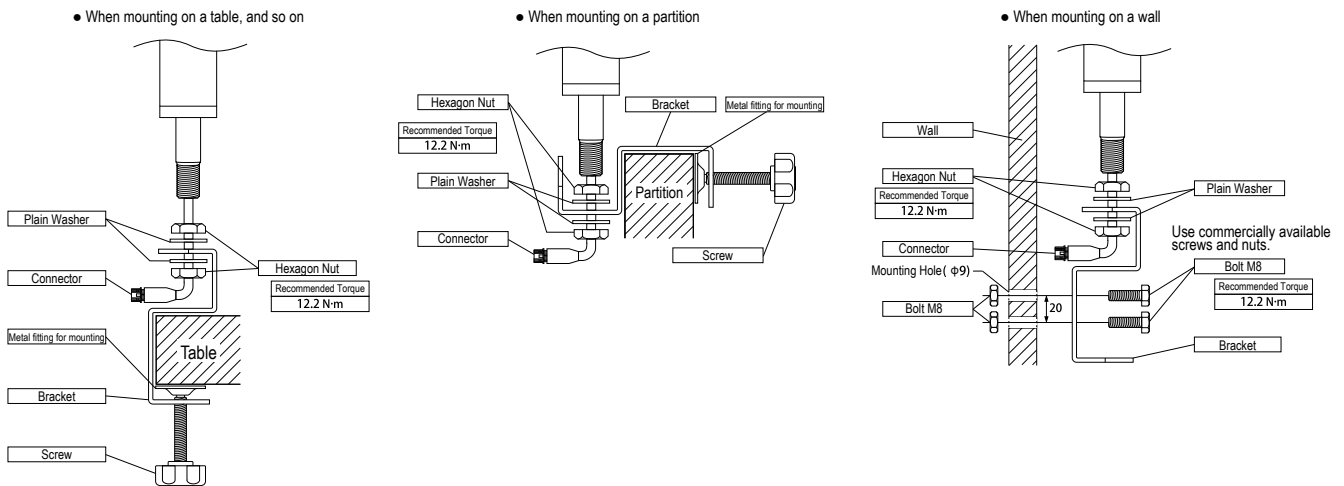

Wiring Diagram

- Connect the Signal Tower cable and AC Adaptor to the switch box connector and DC jack. Apply the rated voltage to the AC Adaptor's AC plug. Each time you press the switch, the corresponding color on the Signal Tower's LED Unit turns on and off.

Switch status	
Light off	Lighting
Switch	Switch

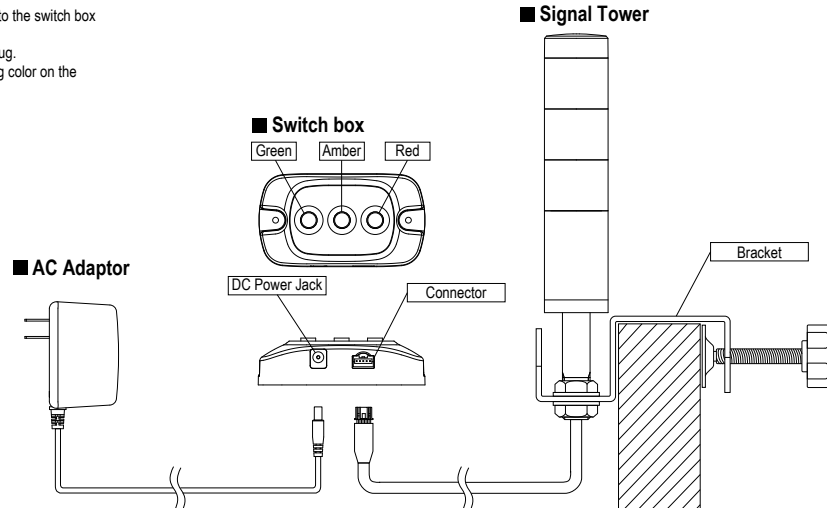

Network

Signal Tower

Signal Light

Revolving Warning Light

Cube Tower

Audibles

Hybrid Signaling Devices

LED Illumination

Options